

Please read through this User's Manual before use for correct handling.  
Please keep this User's Manual for future reference.

## 1. CAUTIONARY NOTES FOR SAFE USE OF THE PRODUCT

This User's Manual should be carefully read before installing and operating the product. The following symbol is used on the product and in this manual to ensure safe use.



**This symbol is displayed on the product when it is necessary to refer to the User's Manual for information on personnel and instrument safety. This symbol is displayed in the User's Manual to indicate precautions for avoiding danger to the operator, such as an electric shock.**

The following symbols are used only in this manual.



### IMPORTANT

**Indicates that operating the hardware or software in a particular manner may cause damage or result in a system failure.**



### NOTE

**Draws attention to essential information for understanding the operations and/or functions of the product.**

## 2. CHECKING PRODUCT SPECIFICATIONS AND PACKAGED ITEMS

### (1) Checking the Model and Product Specifications

Check that the model and specifications indicated on the nameplate attached to the side face of the main unit are as ordered.

### (2) Packaged Items

Check that the packing carton contains the following items:

- VJA5: 1
- Tag number label: 1 sheet
- User's Manual (this manual: IM 77J01A05-01E): 1 copy

## 3. GENERAL

This plug-in type distributor is used in combination with a two-wire type transmitter to calculate the square root of 4 to 20 mA DC input signals from the transmitter and then convert them into isolated DC current or DC voltage signals.

## 4. MOUNTING METHOD



### NOTE

**Insert/pull out the main unit into/from the socket vertically to the face of socket. Otherwise the terminals are bent and it may cause a bad contact.**

### 4.1 Wall Mounting

Loosen the main unit-fixing screw of the product and pull out the main unit from the socket. Fix the socket on the wall with screws. Next, insert the main unit into the socket and fasten the main unit with the main unit-fixing screw.

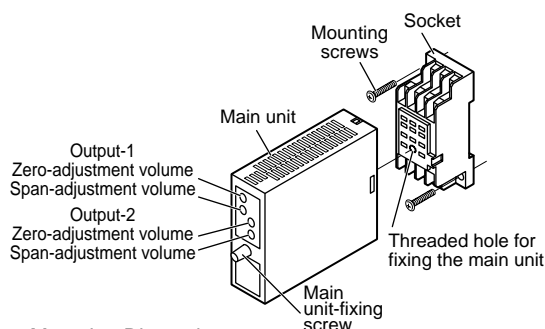

<Mounting Dimensions>

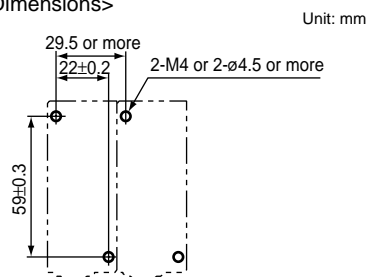

### 4.2 DIN Rail Mounting

Insert a DIN rail into the upper part of the DIN rail groove on the rear of the socket, and then slide the slide lock at the lower part of the socket upwards until the socket is fixed into position as shown below.

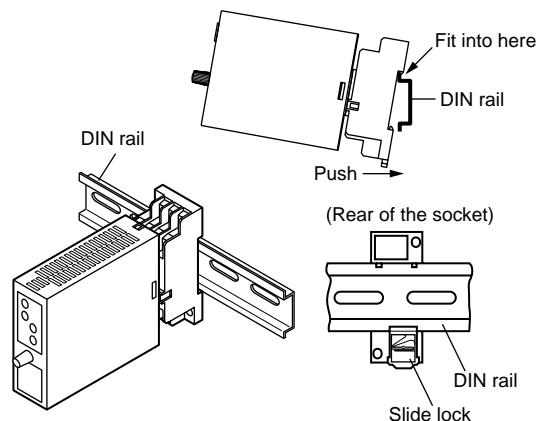

### 4.3 Mounting Using a Multi-mounting Base

When using a multi-mounting base, see the User's Manual for VJCE (VJCE Mounting Base).

### 4.4 Using a Duct

When using a wiring duct, install the duct at least 30 mm away from the top and bottom faces of the main unit.

## 5. INSTALLATION LOCATIONS

- Avoid the following environments for installation locations: Areas with vibration, corrosive gases, dust, water, oil, solvents, direct sunlight, radiation, a strong electric field, and/or a strong magnetic field
- If there is any risk of a surge being induced into the power line and/or signal lines due to lightning or other factors, a dedicated lightning arrester should be used as protection for both this unit and a field-installed device.

## 6. EXTERNAL WIRING



### WARNING

**To avoid the risk of an electric shock, turn off the power supply and use a tester or similar device to ensure that no power is supplied to a cable to be connected, before carrying out wiring work.**

Wiring should be connected to the terminals on the socket of the product. The terminals for external connections are of M3 screws. Use crimp-on terminal lugs for connections to the terminals.

- Recommended cables: A nominal cross-sectional area of 0.5 mm<sup>2</sup> or thicker for signal cables, and that of 1.25 mm<sup>2</sup> or thicker for power cables.

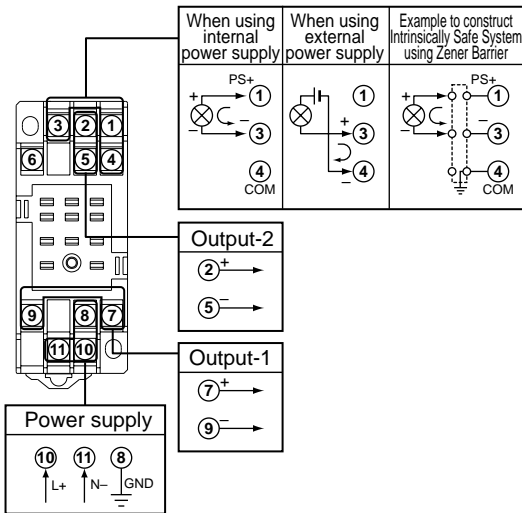

### IMPORTANT

- The power line and input/output signal lines should be installed away from noise-generating sources. Other wise accuracy cannot be guaranteed.
- The grounding resistance must be 100 Ω (JIS Class D grounding). The length and thickness of the grounding cable should be as short and thick as possible. Directly connect the lead from the ground terminal (terminal no. 8) of the product to the ground. Do not carry out daisy-chained inter-ground terminal wiring.
- Use of the product ignoring the specifications may cause overheating or damage. Before turning on the power, ensure the following:
  - (a) Power supply voltage and input signal value applied to the product should meet the required specifications.
  - (b) The external wiring to the terminals and wiring to ground are as specifications.
- Do not operate the product in the presence of flammable or explosive gases or vapors. To do so is highly dangerous.
- The product is sensitive to static electricity; exercise care in operating it. Before you operate the product, touch a nearby metal part to discharge static electricity.

## 7. MAINTENANCE

The product starts running immediately when the power is turned on; however, it needs 10 to 15 minutes of warm-up before it meets the specified performance.

### 7.1 Calibration Apparatus

- A DC voltage/current standard (Yokogawa 7651 or the equivalent)
- A digital multimeter (Yokogawa 7561 or the equivalent)
- A precision resistor of 250 Ω ± 0.01%, 1 W

### 7.2 Calibration Procedure

- (1) Connect the instruments as shown below. First adjust the output-1 signal and then the output-2 signal.
  - (2) Use the DC voltage/current standard and apply input signals equivalent to 0, 6.25, 25, 56.25, and 100% of the input span to the product. Check to see the corresponding output voltages are 0, 25, 50, 75, and 100% respectively and within the specified accuracy rating. "R" is used for current output.
- If the output signals are out of the accuracy rating range, adjust the output signal level using the zero and span adjustment volumes on front face of the product.

